

Why is the Rota-Loo the right composting toilet for me?

Because Rota-Loo's are...

- waterless.
- odourless.
- easy to install.
- easy to maintain.
- converts fresh waste into organic humus.
- approved in every state.
- one of the world's finest composting toilets.

Many of our friends and customers have chosen an alternative lifestyle, opting to be self sufficient rather than connecting to a sewerage system that exploits precious resources and creates pollution. Some of our customers have an environmental or ethical reason for choosing Rota-Loo and some just wanted to save money. If we had to generalize on why most people choose Rota-Loo, we would have to say.....

"There are hundreds of good reasons for choosing a Rota-Loo"

The Rota-Loo comes in a variety of sizes for all applications. When installed correctly the ROTA-LOO provides the optimum conditions for the natural hygienic process of composting to occur. Composting is the most appropriate method for dealing with human waste and is completely natural. A composting toilet is traditionally a waterless toilet and therefore respects precious water supplies and doesn't create any pollution. Because the Rota-Loo doesn't use water to transport deposits from one place to another the Rota Loo must sit directly below the toilet room. In your toilet room there is no chain to pull or button to press, apart from that it's your average loo.

Some of the key Rota-Loo features are...

- Inside a precision built Rota-Loo are six removable compost bins housed on a turntable.
- The turntable is manually rotated once a bin becomes full.
- The full bin remains inside the system to continue the composting process.
- Once a composted bin comes around for use again the contents will be reduced to two thirds of it's original volume and transformed into a soil rejuvenating humus.
- There is no strenuous raking, bending or digging of any fresh waste
- The Rota Loo has the lowest profile of any composting toilet.
- Virtually no maintenance.
- Unlimited capacity ...and the toilet room is always fresh.

One of the most significant benefits of the Rota-Loo system is its ability to use spare bins. If an installation receives a shock loading and all the bins become full before the first has fully composted, a spare bin can be put in its place and the other removed to finish composting in a safe place.



The Rota-Loo comes in a variety of sizes for all applications.

Sizes:

Rota-Loos are made in several sizes. The number of people that each size is suited to will vary, depending on the installation and the favourable composting conditions that can be generated.

The smallest unit is the Rota-Loo 650. This unit was designed for use in holiday homes with only one toilet pedestal and for homes with minimal clearance. With a good installation, the 650 will cater for 4 people on a full-time basis.

The largest domestic Rota-Loo is the 950. As its name suggests it physically stands 95cm tall and 120cm in diameter. The Rota-Loo 950 has more than twice the capacity of the 650 but is only 30cm taller. For continuous use we always recommend the Rota-Loo 950 first.

In a good installation in an optimum environment, the 950 will cater for a large family of up to 8 people. If the installation of any composting toilet is poorly done or in a cold climate then the units capacity will be diminished. The 950 also has the capacity to take two pedestals on the same unit. Please check with your distributor for the correct advice on which unit will best suit your needs.

The other units available in the Rota-Loo range and for which separate brochures are available are:

- The Rota-Loo 101, it comes in kit form and is designed for use in developing countries
- The Mobile Rota-Loo, as a transportable or high altitude composting toilet,
- The Maxi Rota-Loo, for commercial facilities normally using a Soltran Building(tm).

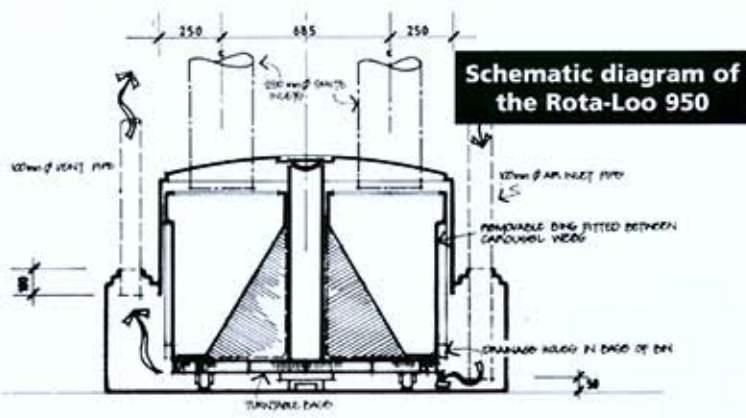

Schematic diagram of the Rota-Loo 950



Why is there no smell?

Some people think that all composting toilets smell. This is definitely not the case with the Rota-Loo system. The smell that one normally associates with sewerage or septic tanks is actually caused by anaerobic bacteria. These are formed when too much water or liquid is mixed with urine and faecal material. The Rota-Loo being a waterless system is designed to remain aerobic and not produce odour. Each of the six internal composting bins has a filter in the bottom. This means that all solids are retained in the bin and liquids are allowed to separate. From this it is plain to see that the process is completely aerobic and smells are minimised. The other safeguard you have with the Rota-Loo system is the convenience of being able to put a fan into the system, there is a fan available for every common power supply. Air continually being pulled through the Rota-Loo to the vent, creates a negative pressure at the pedestal. This means that a small amount of air is always being taken from the toilet room ...keeping it nice and fresh

of this pedestal is quite significant. The separating pedestal can help in the elimination of odours whilst increasing the rate of decomposition and evaporation. This development allows for efficient operation in cooler climates or where optimal conditions cannot be met. The amount of liquid in the pile will be significantly reduced leaving the system in an aerobic condition. You can choose from a sturdy white fibreglass pedestal (above right) or a classically shaped ceramic unit in straight through or separating mode.

One of the World's finest composting toilets.

Evaporation and Rates of Composting:

The advantage of having a continuous airflow gives the ability to evaporate liquid which has drained through the bin and is collected in the base of the Rota-loo under the turntable. For every 10 degrees of heat that can be generated or brought into the system the composting rate can be doubled and the evaporation rate significantly increased. The site and installation of the Rota-Loo is therefore very important. The air inlet for the Rota-Loo should be placed in an area or position where naturally warmed air occurs and the system should be insulated, preferably in a dedicated room. Where possible a small Soltran module can be incorporated into the building design to provide the ultimate environment for the composting system. Not everyone is able to provide the best possible environment for their composting toilet so our distributors are able to advise on the best place for your Rota-Loo to be installed. They have learnt from our 3 decades of experience in the business.



26/01/2009

Pedestals:

One of the latest innovations to come from our research program is the development of the "Separating Pedestal". The importance

ROTALOO W.A.
 PO BOX 2 GLEN FORREST
 WESTERN AUSTRALIA 6071
 PH 92956838 Mob 0412587828
 email : mail@michaelward.com.au



Manufactured by:
Environment Equipment Pty Ltd
 A.B.N. 53 064 489 854
 5/67 Industrial Drive, Braeside
 VIC 3195 Australia
 Freecall 1800 250 950
 Ph: +61.03 9587 2447
<http://www.rotaloo.com>