

Rota-Loo 650 Installation Notes

This information has only been designed to give you a general overview of the installation of a Rota-Loo 650 your installation will be influenced by building design and site conditions. These notes do not cover the principles and science of composting.

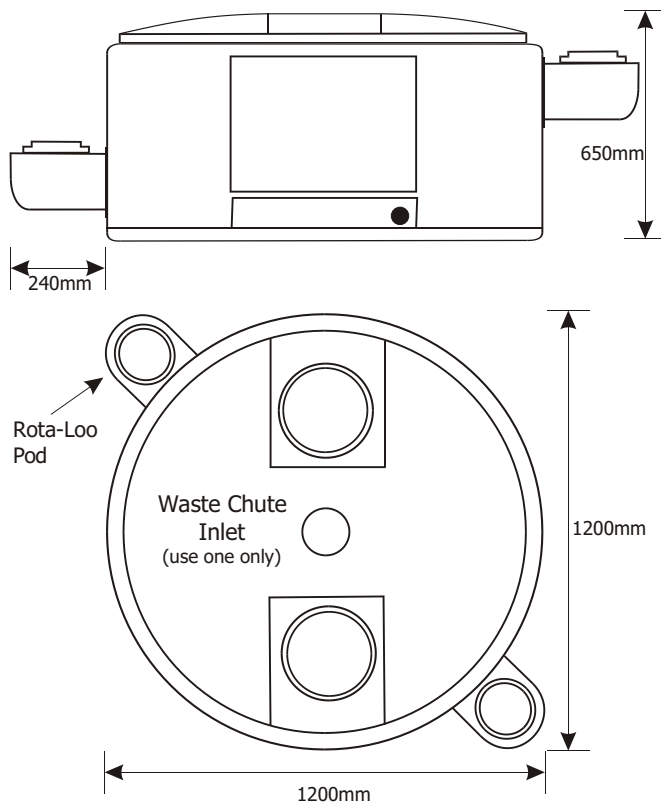

The above dimensions are for the Rota-Loo only and they do not include any Air Inlet, Vent Pipe or Waste Chute connections.

Pedestal

The pedestal needs to be located directly above the Rota-Loo. The length of the waste chute will be determined by your particular installation. Only one pedestal should be connected to the Rota-Loo 650. We recommend A minimum of 300mm from the base of the Pedestal to the top of the Rota-Loo.

Maximising Heat

Where and how the Rota-Loo is installed is a significant part of the composting equation. Do not underestimate the importance of acquiring and maintaining heat in the Rota-Loo. The heat is used to increase decomposition, help to evaporate the liquid and to kill pathogens. Options include locating the Rota-Loo in a sunny location preferably on the north side of the building or placing the Air Inlet in a Soltran. A Soltran is a lean-to glass house, angled at 60 degrees and north facing. Glazing can be twinwall polycarbonate, double glazing (glass) or a clear UV treated material (check with manufacturers regarding heat loss and life span of the material) see installation drawing. The Rota-Loo should be well insulated.

It is also important to remember that warm air naturally rises and does not like going around sharp corners so only use 45 degree bends.

Liquid Build-Up

Without sufficient heat, liquid build-up can occur and will create odours. Connecting the Rota-Loo to an Absorption Trench or container and regularly adding baulking material will help to alleviate any site or installation problems. The use of a Separating Pedestal insert will allow you to divert the liquid directly to a Absorption Trench or to the bottom of the Rota-Loo, this will make the evaporation of liquid easier as well as creating a better Carbon/ Nitrogen balance in the pile.

Sub Floor Space - Stumps

Stump spacings do vary, if the Rota-Loo does not fit your stump spacings please consult the relevant engineer to discuss your particular installation issues.

Slab Floor

A Rota-Loo can be housed in a full or partial cellar, see the notes on "Maximising Heat"

Fan

A Mains or Solar powered fan is located in the Vent Pipe. The purpose of the fan is to, (1) Draw warm air into the Rota-Loo to encourage the composting activity, (2) To help with the evaporation of liquids and (3) To draw any possible odours down from the toilet cubicle. It is important that the air inlet is located lower than the pedestal, otherwise the fan will only draw the air from the toilet cubicle. The fan should be installed At 45 degrees. If the Rota-Loo is located in a holiday home the fan could be connected to a timer to help conserve power.

Air Inlet and Vent Pipe Connections

The Air Inlet and Vent Pipe Connections must be located diagonally opposite each other. 100mm DWV pipe is not supplied when you order a Rota-Loo.

Rotation of the Top

The lid can be rotated by undoing the Self Taping screws, but before you do this, consider the issue of aligning the bin under the Waste Chute.

Location of the Unit

Rota-Loo's do not require water so they can be located away from other house utilities. Placing a Rota-Loo on the north side will not necessarily interrupt the energy efficiency of your home, see the various brochures and folders produced by Energy Victoria regarding "optimum area of glass".

Space Required

There is no "one set of measurements" which will suit all applications, you will need enough space to locate the Rota-Loo, enough space around the Rota-Loo to install the Air Inlet and Vent Pipe, enough space above the Rota-Loo to install the waste chute and you will need enough space to service and maintain the unit.

The following page only shows one of the many alternatives available.

Rota-Loo 650 Installation Notes

This is only one of the many installation suggestions available, For more information regarding your particular installation please contact our nearest distributor.

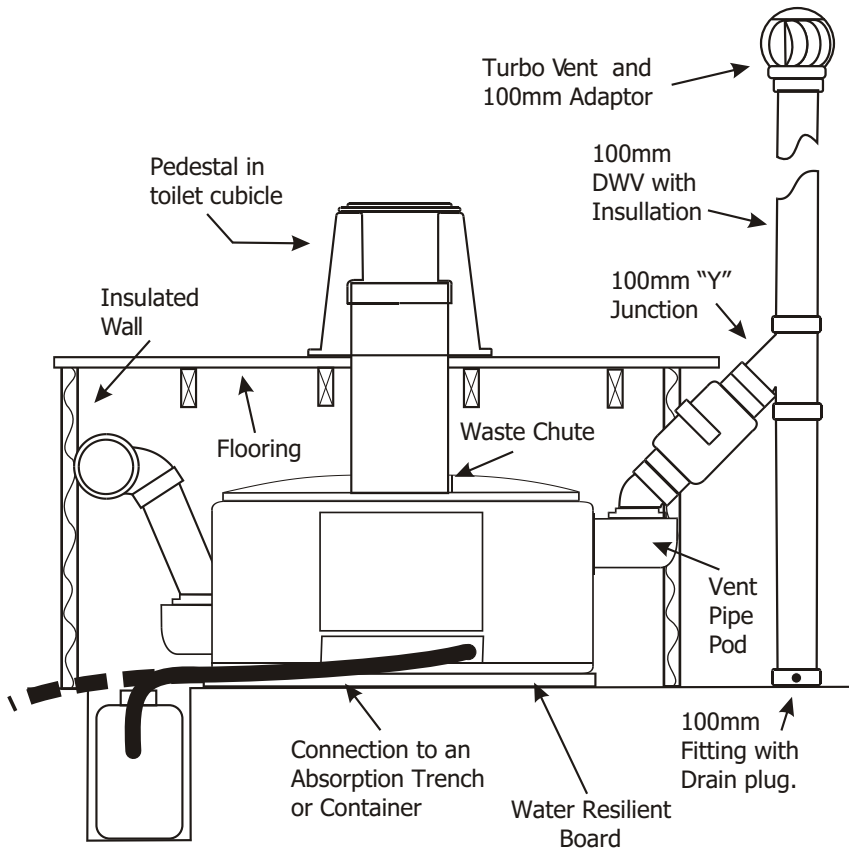

You will need enough space to:

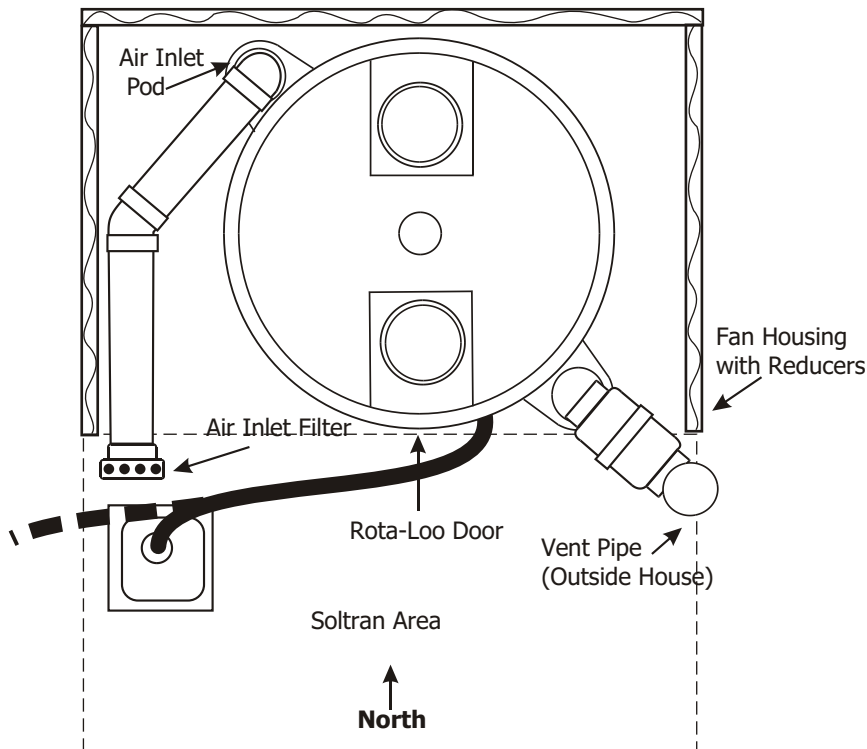
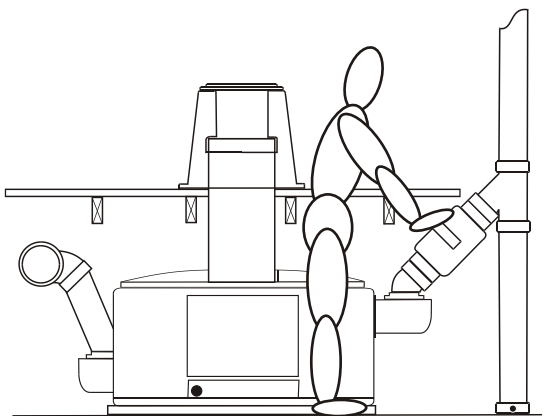
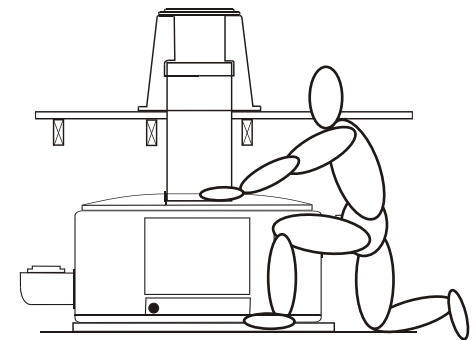
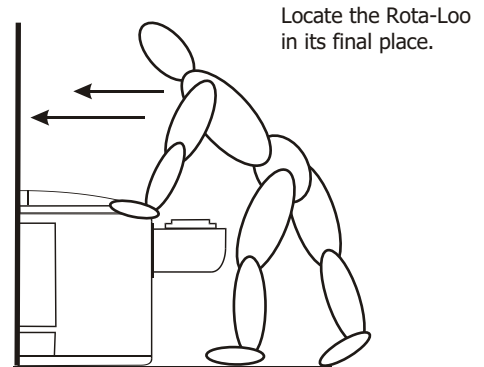

The Soltran Principle

Clear sheeting is angled at 60 degrees. The rays of the sun heats up the cool air inside, the warm air is drawn into the Rota-Loo by the fan in the Vent Pipe. The front of the Soltran can also be used as the access door to the Rota-Loo room.

